



OSMONICS

ENGINEERING PURITY



Autotrol® Performa Cv™ Twin Systems

Product Specifications

The Performa Cv Twin Systems are a sophisticated twin-tank design, created for efficiency and convenience in a variety of applications. Incorporating an intelligent microprocessor control and water meter, the Autotrol Performa Cv Twin System electronically monitors water usage and regenerates each valve at the appropriate time to provide an uninterrupted supply of treated water. The Autotrol Performa Cv Twin System's ease of operation is equaled only by the uncommon reliability of the Autotrol Performa Cv control valve with its simple design and reinforced Noryl™ construction.*

■ Autotrol Performa Cv Twin Alternating System

For use in residential and commercial applications, the Autotrol Performa Cv Twin Alternating System measures water flow through a flow meter in the outlet piping. During operation, when capacity of the on-line tank is reached, the main control switches the standby tank into operation and places the on-line tank into regeneration. After completing the regeneration, the control stops in the standby position until the on-line tank becomes exhausted. Prior to coming on-line, the control valve in standby performs an automatic fast rinse to drain, cleansing the tank and provides fresh, soft water to service. During normal operation, the main control displays the capacity remaining and flow rate for the on-line tank.

■ Autotrol Performa Cv High Flow System

The Autotrol Performa Cv High Flow System features a flow rate in excess of 45 gpm at peak conditions. For use in residential and commercial applications, the system measures flow through a 1-inch or 2-inch meter located in the outlet piping. The main control monitors the water usage and allocates half of the water to each tank. When one tank reaches its capacity, it goes into a regeneration and all of the service flow is allocated to the on-line tank. Once the regeneration is complete, the main control decides whether or not to regenerate the other tank and goes through the same process, if needed. Regeneration can be initiated at a defined time or immediately upon bed exhaustion. During normal operation, the main control displays the Capacity of Tank 1, the Capacity of Tank 2, and the Flow Rate.

*Noryl is a trademark of General Electric Company.

■ System Operation

- The Autotrol Performa Cv Twin Systems operate using two control valves interconnected by a manifold system and control cable.
- The main control, equipped with an easy-to-read, six-digit LED display and interface buttons, is used to program the Autotrol Performa Cv Twin Systems and provide operating instructions to the secondary controls.
- The cycles of regeneration; such as Backwash, Slow Rinse, and Fast Rinse, are adjustable to meet a wide variety of water challenges.
- Salt settings and capacities are programmable to fine-tune the operation and efficiency of the Autotrol Performa Cv Twin Systems.

Water usage information measured by the Performa Cv Twin control system is stored in the main controller's non-volatile memory and is easily accessed. This allows for an in-depth look at the application through a wide variety of water usage and operational information, including:

- Total water used since installation
- Average daily water usage for each day of the week
- Days since last regeneration
- Peak flow rate
- Time of day peak flow rate occurred

■ Estimated Autotrol Performa Cv Twin System Width

Tank Diameter in Inches	14	16	18	21
A	25 inches	27 inches	29 inches	32 inches

Note: Above estimates are for an Autotrol Performa Cv Twin control valve system width and do not include tank width in measurement.

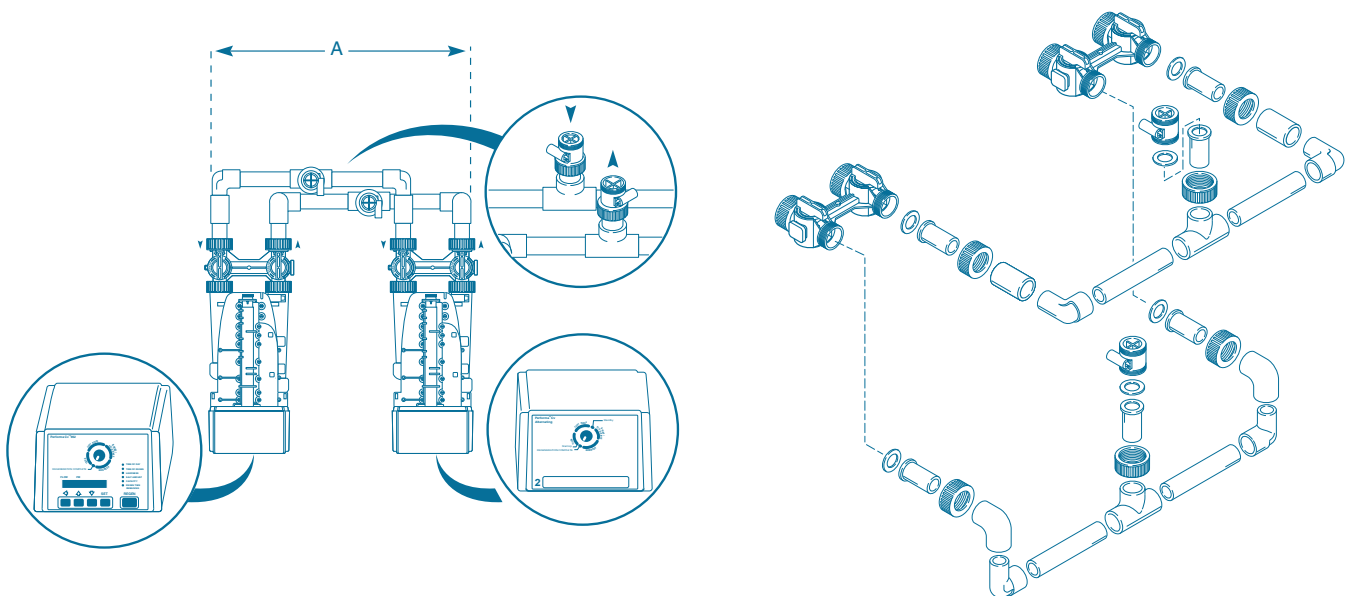

■ Features and Options

- Solid State Microprocessor Provides maximum reliability for long-term, trouble-free service.
- Turbine Operation Single, moving turbine uses Hall-effect sensor to measure water flow. There are no gears or cables to cause mechanical failure.
- NOVRAM (Non-Volatile Random Access Memory) Maintains program data and history data in the event of a power outage.
- LED Display..... Six-digit, easy-to-read display makes viewing and programming simple.
- Standard 278 Valves and 900 Series Controls Standard Performa Cv (278) components mean customer recognition and limited stock of replacement parts.
- Redundant Twin-Valve System..... True twin-tank design provides continuous soft water while allowing one tank to operate independent of the other.
- Optional Remote Regeneration..... Initiation of regeneration is possible from a remote locator or remote device.
- Dura-Flow™ Valve-Disc Technology..... Valve discs are held closed by water pressure and regulate the on- and off-line status of the tanks.
- Manual Regeneration Possible..... Manual regeneration can be initiated with the touch of a button.
- Salt and Capacity Setting Lockout..... Allows you to lock out the salt and capacity settings so they cannot be changed by unauthorized personnel.

■ Individual Valve Specifications

- Hydrostatic Test Pressure 300 psi (20.7 bar)
- Working Pressure 20 to 120 psi (1.4 to 8.3 bar), 100 psi (6.9 bar) max in Canada
- Voltage 85 to 110 VAC 50/50 Hz, 102 to 132 VAC 60 Hz, 204 to 264 VAC 50 Hz, 187 to 242 VAC 50 Hz
- Power..... 4.5 volt-amperes
- Ambient Operating Temperature 34° to 120°F (1° to 49°C)
- Maximum Water Temperature 100°F (38°C)
- Humidity..... 10 to 100%, condensing allowed
- Transformer..... Wall mount with plug options
- Pressure Tank Thread 2-1/2 inches (63.5 mm) - 8 NPSM
- Brine Line Thread..... 3/8 inches (9.5 mm) NPT male or 3/8 JAYCO (9.5 mm)
- Distributor Tube Diameter Required (O.D.)..... 1.050 inch (26.7 mm)
- Distributor Tube Length 1/2 inch ± 1/2 inch (13mm ± 13mm) higher than top of mineral tank
- Valve Module, Optional Bypass Valve Reinforced Noryl
- Rubber Parts Compounded for cold water service
- Injector Size “M” Brown..... See the injector flow rate chart
- Injector Size “Q” Purple See the injector flow rate chart
- Injector Size “R” Dark Gray..... See the injector flow rate chart
- Internal Backwash Controllers Available for..... 14 inches (35.6 cm) diameter mineral tanks
- External Backwash Controllers Available for..... 16-inch, 18-inch, 21-inch diameter mineral tanks (40.6 cm, 45.7 cm, 53.3 cm)

■ Flow Meter Specifications

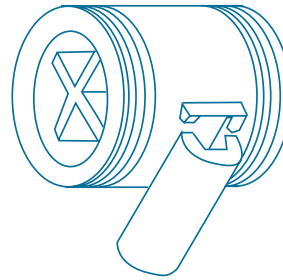
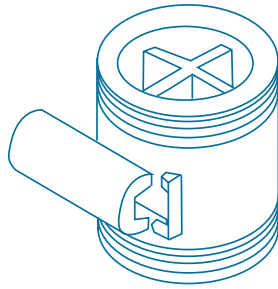

	1-inch Meter	2-inch Meter (Parallel)
■ Normal Operating Range	0.50 - 25 gpm (0.11 - 5.7 m ³ /h)	5 - 150 gpm (1.1 - 34 m ³ /h)
■ Flow Range Rate (Minimum – Peak).....	0.25 - 40 gpm (0.06 - 9.1 m ³ /h)	2 - 250 gpm (0.45 - 60 m ³ /h)
■ Wetted Materials of Construction		
Housing	30% Glass-Filled Noryl	30% Glass-Filled Noryl
Turbine (Impeller)	Polypropylene	Polypropylene
Bearings	Graphite-Filled Acetal	Graphite-Filled Acetal
Shaft	Stainless Steel	Stainless Steel
■ Accuracy Operating Range	±3% of reading	±3% of reading
■ Pressure Drop	1.5 psi @ 30 gpm (0.10 bar @ 6.8 m ³ /h)	2.5 psi @ 150 gpm (0.17 bar @ 34 m ³ /h)
■ Water Temperature Range	34°F - 100°F (1°C - 38°C)	34°F - 100°F (1°C - 38°C)
■ Ambient Operating Temperature.....	34°F - 120°F (1°C - 49°C)	34°F - 120°F (1°C - 49°C)
■ Working Pressure	20 psi - 120 psi (100 psi max Canada)	20 psi - 120 psi (100 psi max Canada)

■ Injector Flow Rate Chart

psi (Kg/cm)	M Injector		Q Injector		R Injector	
	Draw	Rinse	Draw	Rinse	Draw	Rinse
	gpm (Lpm)	gpm (Lpm)	gpm (Lpm)	gpm (Lpm)	gpm (Lpm)	gpm (Lpm)
20 (1.4)	0.3 (1.1)	0.5 (1.9)	0.4 (1.5)	0.9 (3.4)	0.45 (1.7)	1.2 (4.5)
30 (2.1)	0.4 (1.5)	0.55 (2.1)	0.5 (1.9)	0.95 (3.6)	0.5 (1.9)	1.3 (4.9)
60 (4.2)	0.6 (2.3)	0.8 (3.0)	0.82 (3.1)	1.4 (5.3)	0.09 (3.4)	1.75 (6.6)
80 (5.6)	0.7 (2.6)	0.85 (3.2)	0.9 (3.4)	1.6 (6.0)	1.0 (3.8)	2.0 (7.6)
100 (7.0)	0.7 (2.6)	0.9 (3.4)	0.95 (3.6)	1.8 (6.8)	1.1 (4.2)	2.2 (8.3)

Call for additional information, (888) 577-8088, or visit www.aclear.com



OSMONICS

A Clear Alternative
 Water Conditioning & Bottled Water
 230 Collins Avenue
 Pennsauken, NJ 08110
 (888) 577-8088 Phone